

EZ-SERV® Wall Mount Dispenser

Model: EZ540 | Specification Sheet



SPECIFICATIONS

Dimensions:

8 x 8 x 23.5 IN / 20.3 x 20.3 x 59.7 CM

Label Size for Label Holder:

2.5 x 1.63 IN / 6.4 x 4.1 CM

Container Capacity: 3.5 Gallons / 13.2 Liters

Product Weight: 5.2 Pounds / 2.4 Kilograms

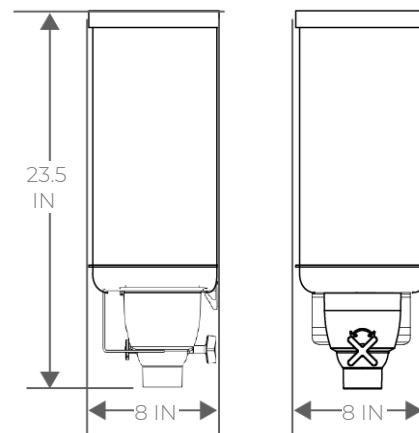

Parts List

Item Description	Item Number	Material
a. Metal Wall Mount	EZ540-M	Steel
b. Grey Lid	EZL018	ABS
c. Container Shell	EZC019	Acrylic and ABS
d. 1 oz. Portion Wheel	EZP021	Silicone and ABS
e. 1 tbsp. Portion Wheel	EZP022	Silicone and ABS
f. 1, 2, 3 & 4 tsp. Portioned Scoops	EZP028	Silicone and ABS
g. Label Holder	EZM036	ABS
h. Metal Handle	EZH010	Zinc Alloy

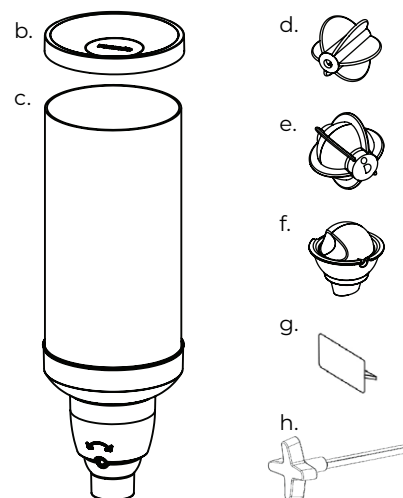

CLEANING & CARE INSTRUCTIONS

- **DO NOT** put any part of the unit through dishwasher or dryer machine. **ALWAYS** use a non-abrasive sponge.
- **Container Care:**
 1. To maintain the quality of your EZ-SERV® container, wash all parts in warm water with a mild soap.
 2. When disassembling the container, handle all parts gently. Please refrain from using too much force.
 3. Reassemble the unit only after all parts are completely dry.
- **Steel Care:**
 1. Wipe down with damp microfiber cloth and always wipe dry with a microfiber cloth. Keep away from heat and direct sunlight. Store in a dry and well-ventilated place.

R1 09242019

NEED ASSISTANCE?

Customer Service Support: **847-763-1215**

Address: **3714 Jarvis Avenue Skokie, IL 60076**

Website: **www.rosseto.com**

