

# Multi-Chef™ Square Warmer with Round Grill

Instruction & Specification Sheet for Models SK085 and SK086

## BEFORE YOU BEGIN

Be sure to read all the instructions before attempting to use the Multi-Chef Warmer. Proper care and maintenance will extend the life of your new Warmer. **Save these instructions for future reference.**

- Carefully unpack and inspect all parts. If a part appears to be damaged or missing, please contact Rosseto Customer Service.
- Handle all parts carefully when moving, storing, or cleaning to avoid damage. Be sure to follow the Care and Cleaning instructions.

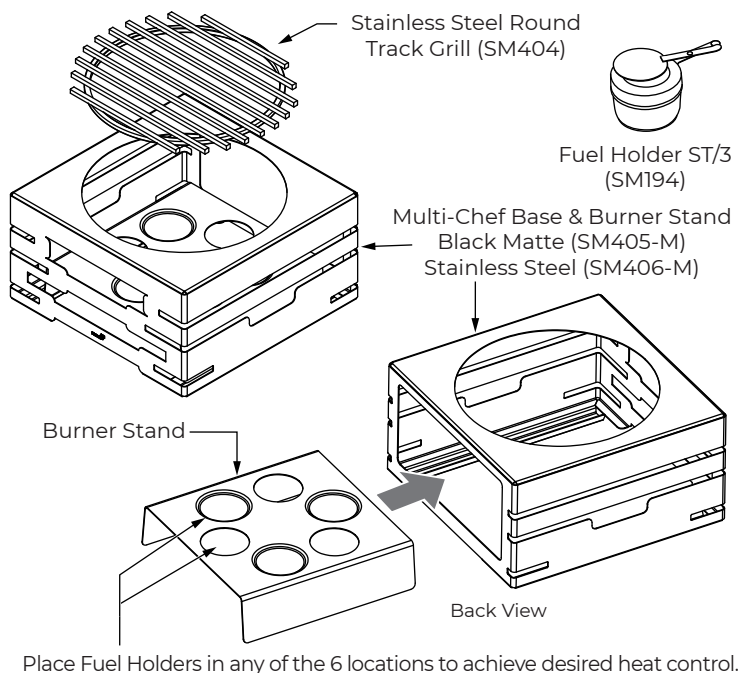

## IMPORTANT SAFEGUARDS

2. Place the Multi-Chef Warmer on a flat, firm, dry surface. Do not operate the Warmer on a plastic or soft tablecloth.
3. Do not overfill the food warming vessel being used to avoid contents from spilling over during use.
4. **Never let the Warmer operate without supervision.** Children should not operate the Warmer.
5. Do not operate the Warmer in an area where gasoline, paint, or flammable liquids are used or stored.
6. The Track Grill may remain hot after use. Always let the Track Grill cool before handling.
7. **Do not cook any food directly on Track Grill.**

## OPERATING INSTRUCTIONS

1. Place the Warmer Base on a flat, firm, dry and safe surface.
2. Slide the Burner Stand into the Warmer Base. See figure at left.
3. Place heat chafing fuel into the Fuel Holders. Fuel Holders may be placed at two different levels in the Burner Stand depending on desired heat control. Light the chafing fuel.
4. Place the Track Grill on top of the Warmer Base. The Warmer is now ready for use.
5. The back of the Warmer Base has a large "opening" that has been designed specifically for easy placement of the Fuel Holder in the event that the chafing fuel needs to be changed during use.

## CARE AND CLEANING

1. Do not use any caustic cleaning agents or abrasive scrubbing pads on any part.
2. All parts should be wiped with a warm, damp cloth and a mild nonabrasive soap solution.
3. Wipe off the outside of the Warmer with a soft cloth.
4. Make sure that all parts are clean and dry before storing.

## PARTS DESCRIPTION

### Multi-Chef 10" Square Warmer

- SK085 Black Matte Warmer with Stainless Steel Round Track Grill, 3 Fuel Holders, and Burner Stand
- SK086 Stainless Steel Warmer with Stainless Steel Round Track Grill, 3 Fuel Holders, and Burner Stand

## IMPORTANT SAFEGUARDS

When using the Warmer, basic safety precautions should always be observed, including the following:

1. This Warmer is intended to be used for commercial applications such as in kitchens of restaurants, canteens, hospitals, and commercial enterprises; but not for continuous mass production of food.

## SPECIFICATIONS

ASSEMBLED DIMENSIONS	18 X 18 X 10.5 INCHES 45.72 X 45.72 X 26.67 CM
ASSEMBLED WEIGHT	25 lbs/11.34 kg

## NEED ASSISTANCE?

Customer Service Support: **847-763-1215**

Address: **3714 Jarvis Avenue Skokie, IL 60076**

Website: **www.rosseto.com**

