

BEFORE YOU BEGIN

Be sure to read all the instructions before attempting to assemble the Modulite Shelving System.

- Carefully remove all parts from the carton and inspect each part. If a part appears to be damaged or missing, please contact Rosseto Customer Service.

Parts Included in MC-Base Unit

- a 1 Base Assembly
- b 2 Center Frames
- c 2 Upper Frames
- d 28 Allen Screws (4mm Allen Wrench included)
- e 6 Rubber Screw Hole Covers*
- f 1 Back Board
- g 2 Locking Casters
- h 2 Non-locking Casters

Accessories for Module Kit C item #MC-Basic

- i 1 Wire Basket
- j 3 Bamboo Shelves
- k 1 Chalkboard Sign with (2) Hanger Clips

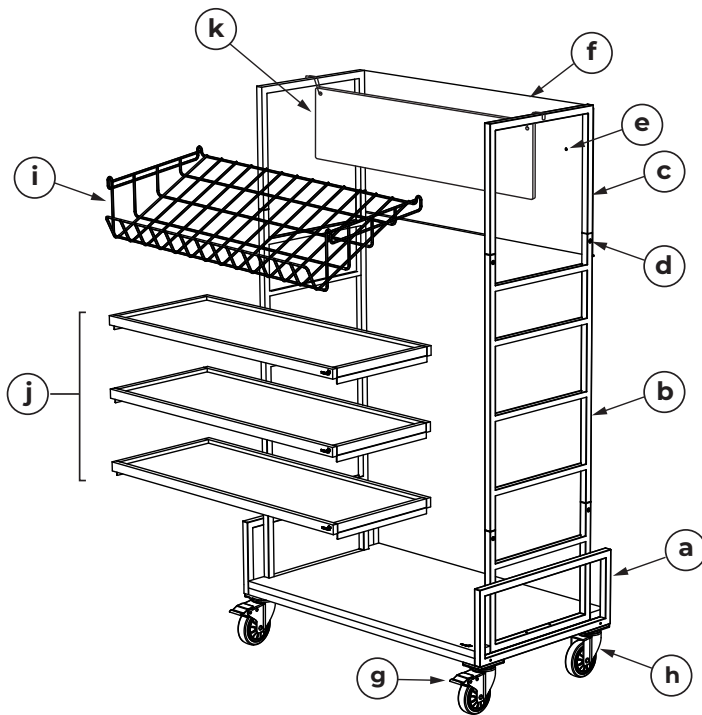

* The Rubber Screw Hole Covers can be used to conceal the holes in the Back Board on units that do not include Container Mounting brackets.

ASSEMBLING THE CART FRAME

Before You Begin

The Base Assembly (a) is already assembled. Note the position of the Rosseto logo as shown in Figure 1 below. The Locking Casters (g) are also shown for reference. As you proceed with the assembly, the logo and the Locking Casters (g) will be on the front side of the frame.

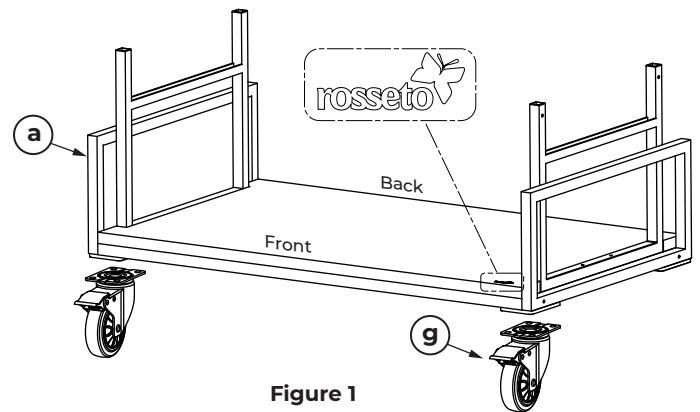

Figure 1

1. Turn the Base Assembly over on a flat surface to install the Casters. Attach the Casters to the Base Assembly (a) using four (4) Allen Screws (d) at each corner. The Locking Casters (g) are mounted on the side of the Base Assembly (a) with the Rosseto logo. Once Locking Casters are installed, then affix the Non-locking Casters (h). See Figure 2 below.

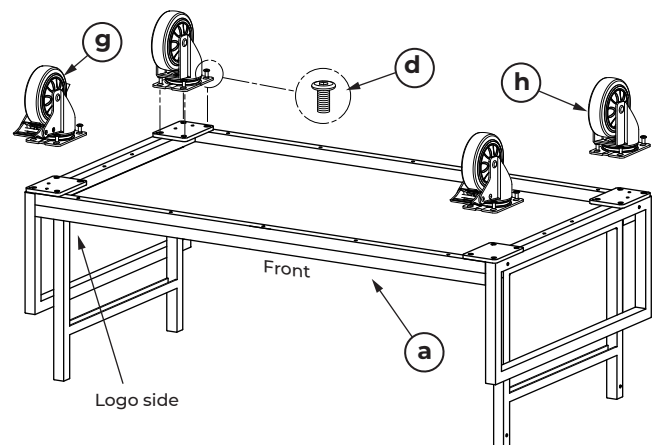

Figure 2



ASSEMBLING THE CART FRAME

- Place the Base Assembly (a) upright on a flat surface. Lock the front Casters (g). Insert both Center Frames (b) into the Base Assembly (a). Install two (2) Allen Screws (d) at the bottom of both the left and right Center Frames as shown in Figure 3. The screw holes face outwards.
- Insert both Upper Frames (c) into the holes in the Center Frames (b). Install two (2) Allen Screws (d) at the top of both the left and right center frames as shown in Figure 3. The mounting pins on the Upper Frames should be facing towards the back.

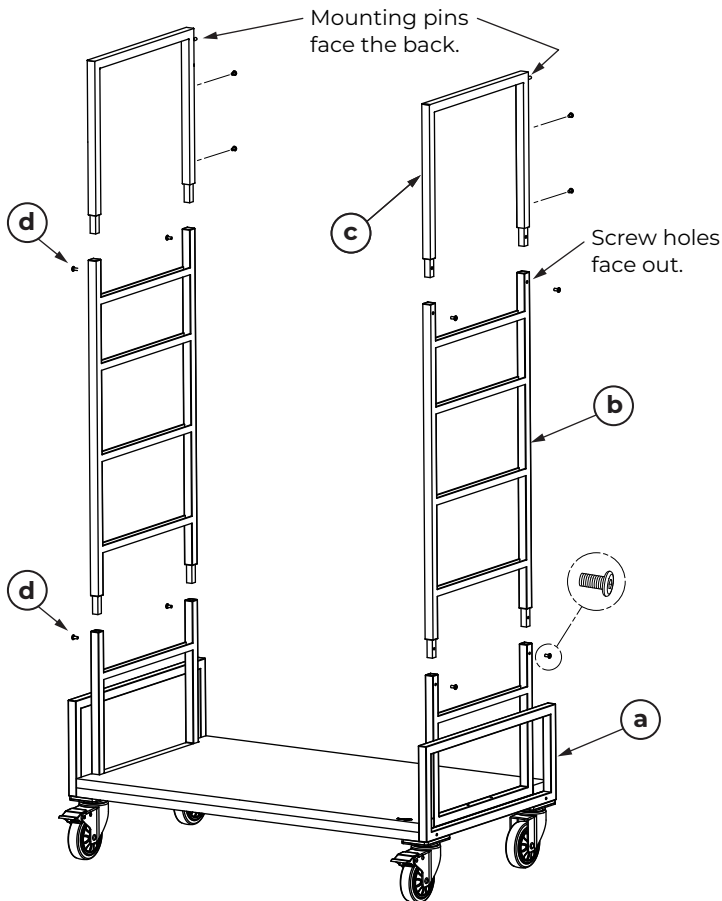

Figure 3

ATTACHING THE BACK BOARD

- Hang the Back Board (f) on the mounting pins. Line up all the holes and install (2) Allen screws (d) on each side of the Back Board (f). Tighten all (4) Allen screws (d). See Figure 4.

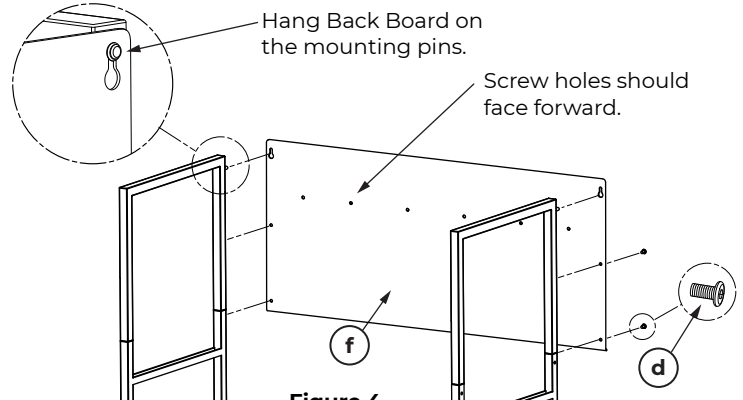

Figure 4

ADDING THE CHALKBOARD SIGN

- To cover the screw holes in the Back Board, insert the (6) Rubber Screw Hole Covers (e) into the holes as shown in Figure 5 below.
- The hanger clips need to be attached on each side of the chalkboard. Place the Chalkboard Sign (k) on the frame. See the detail in Figure 5.

NOTE: Use conventional chalkboard chalk or wet erase chalk markers on the chalkboard sign. See next page for tips on how to care and clean the chalkboard.

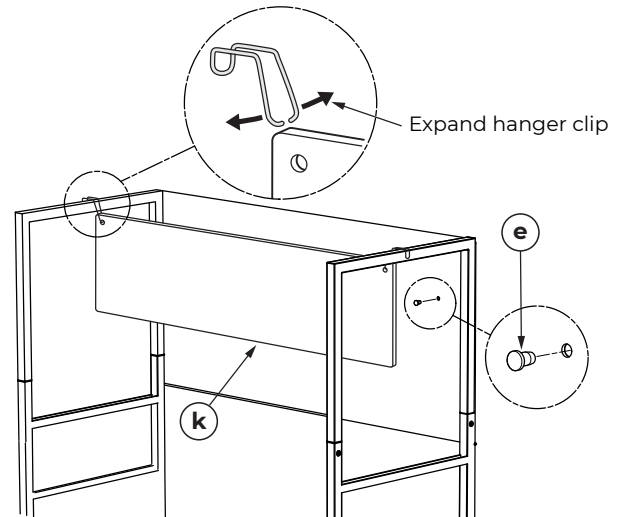

Figure 5



ADDING THE BAMBOO SHELVES AND WIRE BASKET

7. Place the Bamboo Shelves (j) first. Start at the bottom and work upwards, placing the accessories in the order shown in Figure 6 below.
8. Place the Wire Basket (i) last.

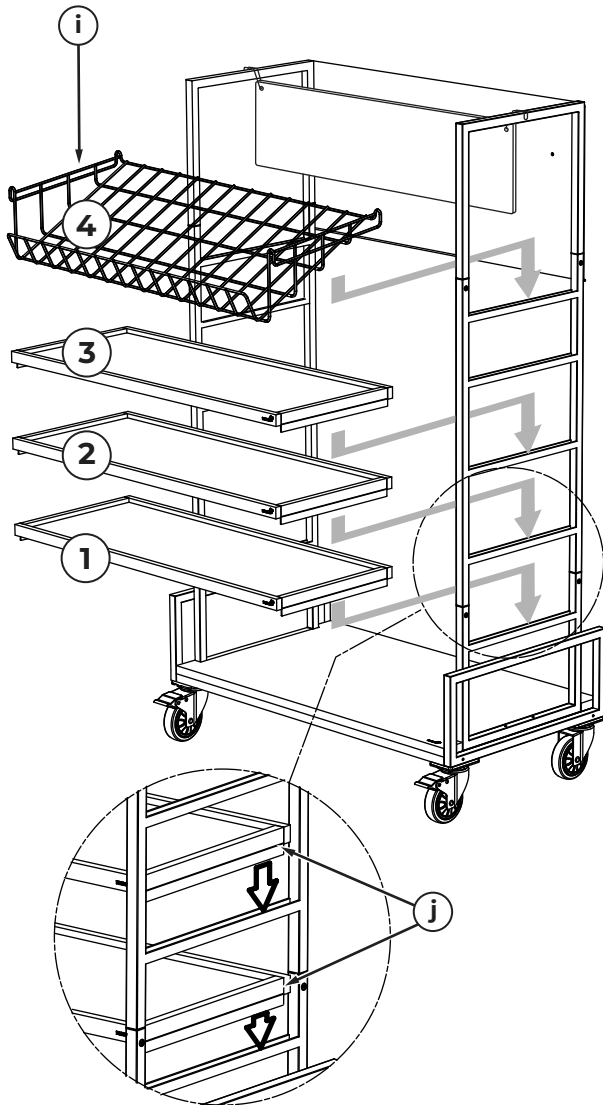

Figure 6

SPECIFICATIONS

ASSEMBLED DIMENSIONS	INCHES	CM
LENGTH	36"	91.44 cm
WIDTH	20"	50.80 cm
HEIGHT	61.5"	156.21 cm

WEIGHT 84 lbs/38.10 kg

CARE AND CLEANING

- DO NOT put any part of the unit through dishwasher or dryer machine. ALWAYS use a non-abrasive sponge.
- DO NOT use any abrasive materials such as scrapers or metal-based brushes.
- DO NOT use harsh chemicals or abrasive cleaners.

Metal Care:

Wipe down with damp microfiber cloth and always wipe dry with a microfiber cloth. Store in a dry and well-ventilated location.

Chalkboard Care:

Suggested Writing Utensil	Cleaning Method
Conventional Chalkboard Chalk	Dry Microfiber Soft Cloth
Wet Erase Chalk Markers	Damp Microfiber Soft Cloth or Melamine foam cleaning sponge

Other safe general cleaning steps for freshening the writing surface.

- For best results, dry-clean the board frequently to prevent chalk dust from building up.
- Remove loose chalk dust with a clean, dry cloth.
- Use warm water with a few drops of mild dish soap or for more stubborn stains, mix equal parts white vinegar and water. Dip a clean soft cloth into the solution, wring it out well, and wipe the chalkboard in long, smooth strokes.
- Use a damp clean cloth to remove excess cleaning solution.
- Allow the chalkboard to air dry or use a clean, dry cloth to wipe off any remaining moisture.

