

#### BEFORE YOU BEGIN

Be sure to read all the instructions before attempting to assemble the Modulite Shelving System.

- Carefully remove all parts from the carton and inspect each part. If a part appears to be damaged or missing, please contact Rosseto Customer Service.

#### Parts Included in MC-Base Unit

- a 1 Base Assembly
- b 2 Center Frames
- c 2 Upper Frames
- d 28 Allen Screws (4mm Allen Wrench included)
- e 6 Rubber Screw Hole Covers\*
- f 1 Back Board
- g 2 Locking Casters
- h 2 Non-locking Casters

#### Accessories for Module Kit B item #MC-PB6

- i 1 Bamboo Shelf
- j 1 Wire Basket
- k PRO-BULK Food Dispenser Mounting Kit— includes (1) Bulk Container Support Shelf and (1) Bamboo Shelf with Catch Tray
- l 6 PRO-BULK Containers (3.5 gallons each) with 1.5 oz. portion wheels, label holders, and false front chambers

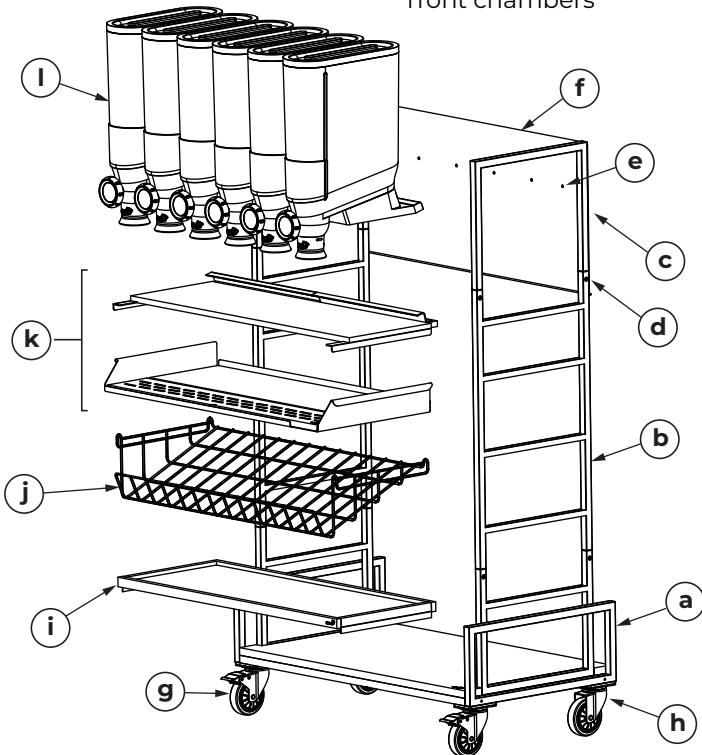

\* The Rubber Screw Hole Covers can be used to conceal the holes in the Back Board on units that do not include Container Mounting brackets.

#### ASSEMBLING THE CART FRAME

##### Before You Begin

The Base Assembly (a) is already assembled. Note the position of the Rosseto logo as shown in Figure 1 below. The Locking Casters (g) are also shown for reference. As you proceed with the assembly, the logo and the Locking Casters (g) will be on the front side of the frame.

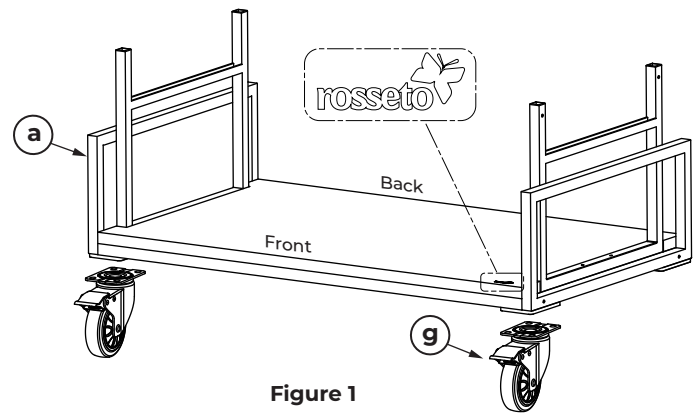

Figure 1

1. Turn the Base Assembly over on a flat surface to install the Casters. Attach the Casters to the Base Assembly (a) using four (4) Allen Screws (d) at each corner. The Locking Casters (g) are mounted on the side of the Base Assembly (a) with the Rosseto logo. Once Locking Casters are installed, then affix the Non-locking Casters (h). See Figure 2 below.

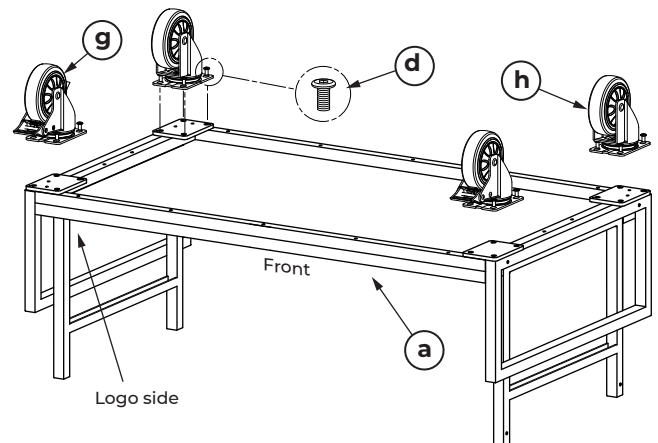

Figure 2



#### ASSEMBLING THE CART FRAME

- Place the Base Assembly (a) upright on a flat surface. Lock the front Casters (g). Insert both Center Frames (b) into the Base Assembly (a). Install two (2) Allen Screws (d) at the bottom of both the left and right Center Frames as shown in Figure 3. The screw holes face outwards.
- Insert both Upper Frames (c) into the holes in the Center Frames (b). Install two (2) Allen Screws (d) at the top of both the left and right center frames. The mounting pins on the Upper Frames should be facing towards the back.
- Hang the Back Board (f) on the mounting pins. Line up all holes and install 2 Allen screws (d) on each side of the Back Board (f). Tighten all 4 Allen screws (d).

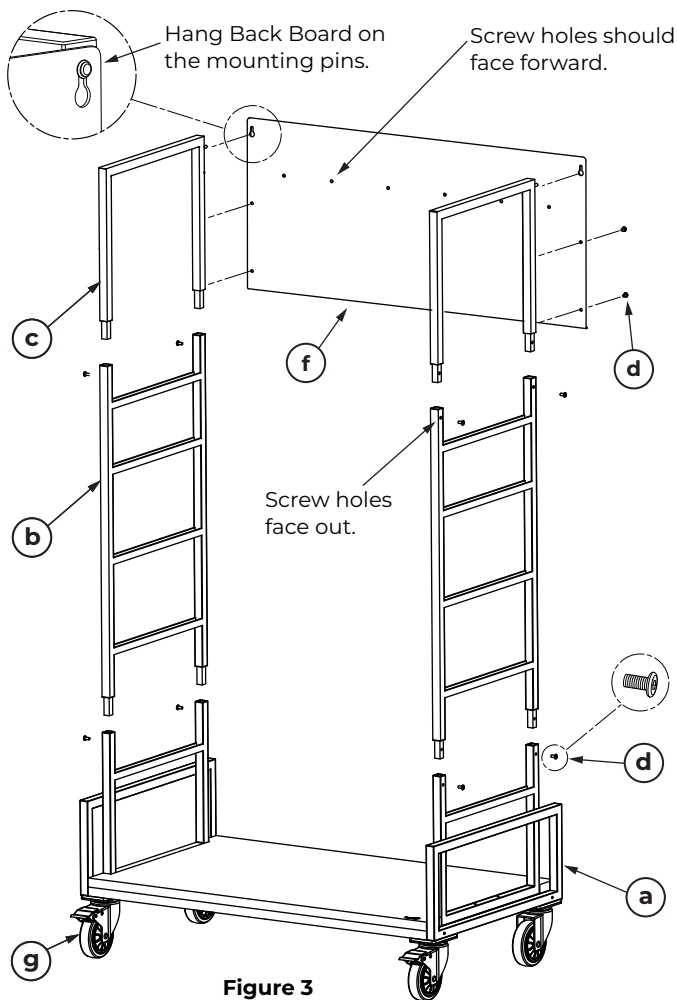

Figure 3

#### ADDING THE ACCESSORIES

- Place the Bamboo Shelf (i) first. Start at the bottom and work upwards, placing the accessories in the order shown in Figure 4 below.
- Place the Bamboo Shelf with Catch Tray last.

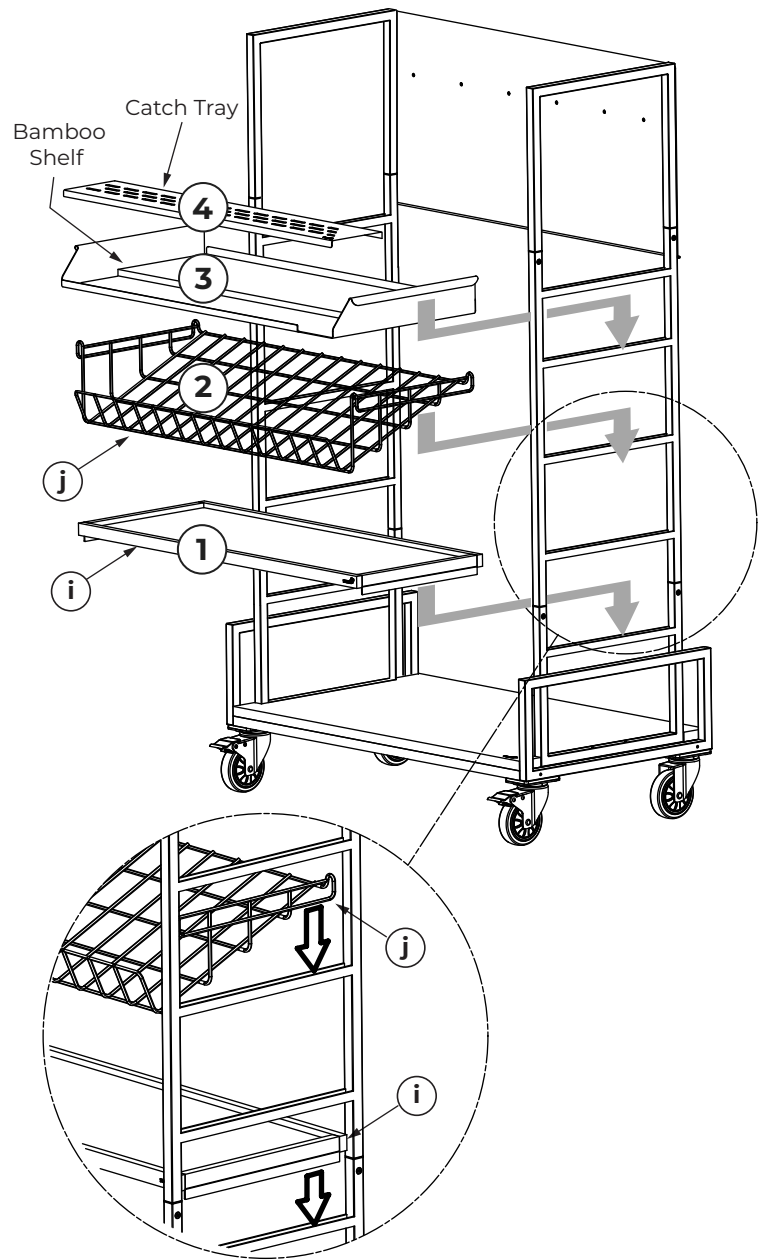

Figure 4



**INSTALLING THE FOOD DISPENSER KIT**

The PRO-BULK Food Dispenser Mounting Kit (K) is shipped in two separate cartons.

7. With the flange facing towards Back Board, angle the Bulk Container Support Shelf between the base frame sides. Then lift the front of the Bulk Container Support Shelf upwards in order to place the flange at the rear of the shelf under the Back Board. At the same time, align both the left and right side rails on the shelf into the side bars of the frame.

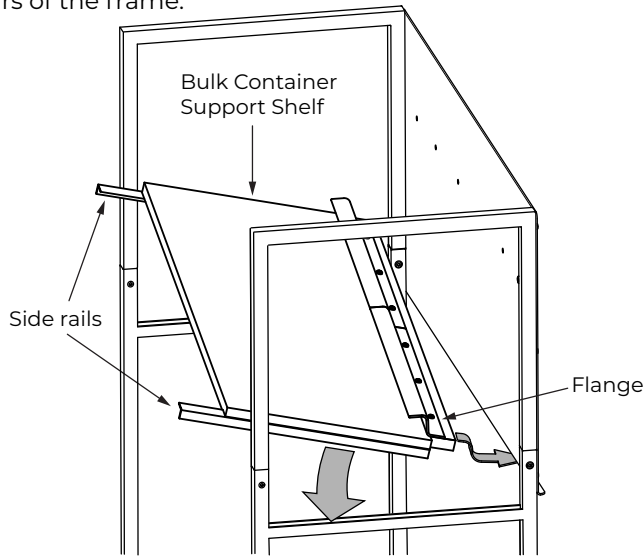

As shown below, once the entire flange is under the Back Board, lower the side rails into the frame.

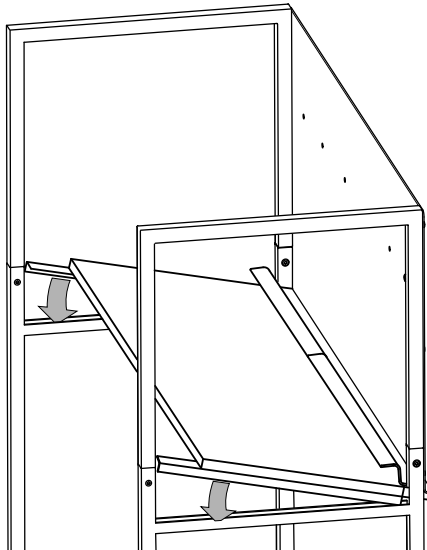

**ADDING THE BULK CONTAINERS**

8. Place the Bulk Containers (1) making sure the back of each Bulk Container is under the metal flange as shown in Figure 5 below.

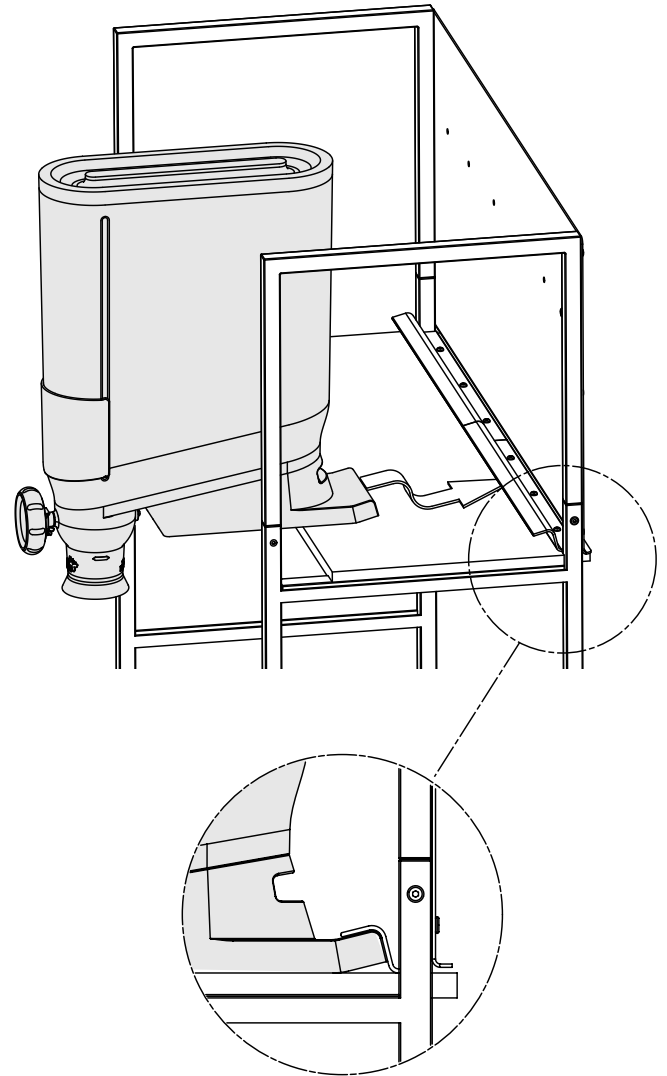

**Figure 5**



# MODULITE™

## Modular & Mobile Shelving System

Instruction & Specification Sheet for #MC-PB6 and MC-PB62

### SPECIFICATIONS

ASSEMBLED DIMENSIONS	INCHES	CM
LENGTH	36"	91.44 cm
WIDTH	20"	50.80 cm
HEIGHT	63"	160.02 cm

WEIGHT 110.5 lbs/50.12 kg

### CARE AND CLEANING

- DO NOT put any part of the unit through dishwasher or dryer machine. ALWAYS use a non-abrasive sponge.
- DO NOT use any abrasive materials such as scrapers or metal-based brushes.
- DO NOT use harsh chemicals or abrasive cleaners.

#### Metal Care:

Wipe down with damp microfiber cloth and always wipe dry with a microfiber cloth. Store in a dry and well-ventilated location.

