

#### BEFORE YOU BEGIN

Be sure to read all the instructions before attempting to assemble the Modulite Shelving System.

- Carefully remove all parts from the carton and inspect each part. If a part appears to be damaged or missing, please contact Rosseto Customer Service.
- Parts Included:
  - e 6 Rubber Screw Hole Covers\*
  - a 1 Base Assembly
  - b 2 Center Frames
  - c 2 Upper Frames
  - d 28 Allen Screws (4mm Allen wrench included)
  - f 1 Back Board
  - g 2 Locking Casters
  - h 2 Non-locking Casters

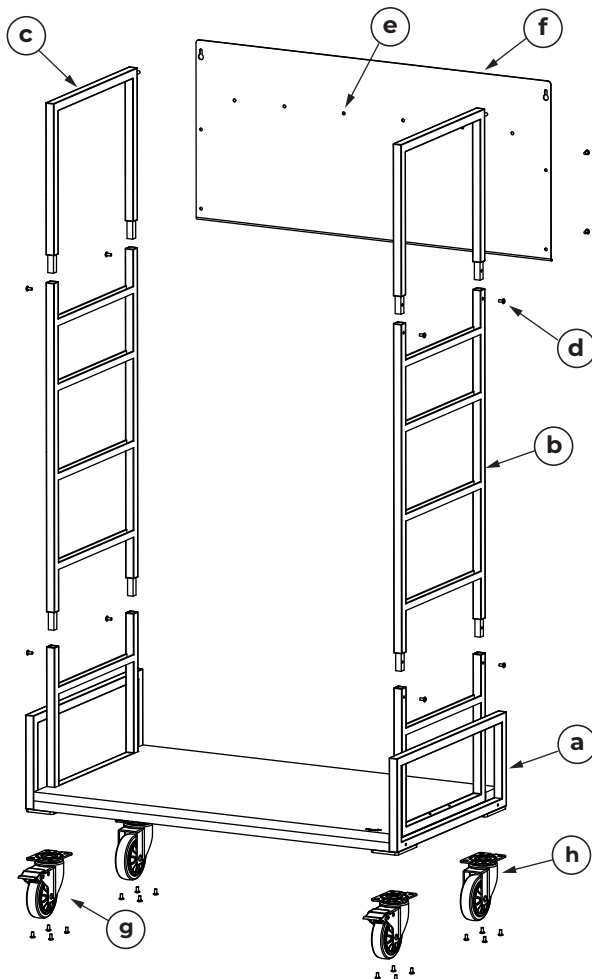

#### ASSEMBLING THE CART FRAME

Before You Begin

The Base Assembly (a) is already assembled. Note the position of the Rosseto logo as shown in Figure 1 below. The Locking Casters (g) are also shown for reference. As you proceed with the assembly, the logo and the Locking Casters (g) will be on the front side of the frame.

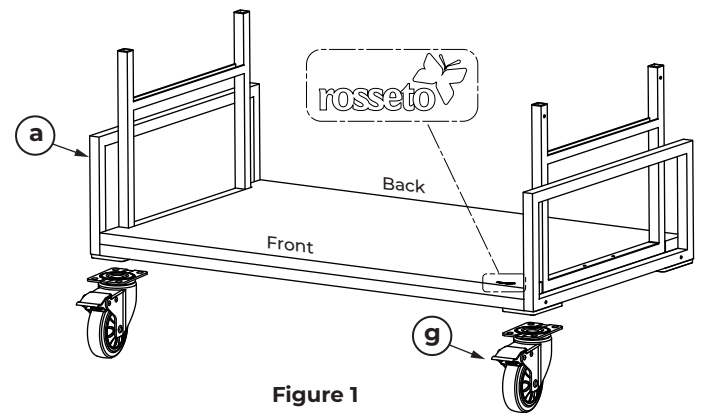

Figure 1

1. Turn the Base Assembly over on a flat surface to install the Casters. Attach the Casters to the Base Assembly (a) using four (4) Allen Screws (d) at each corner. The Locking Casters (g) are mounted on the side of the Base Assembly (a) with the Rosseto logo. Once Locking Casters are installed, then affix the Non-locking Casters (h). See Figure 2 below.

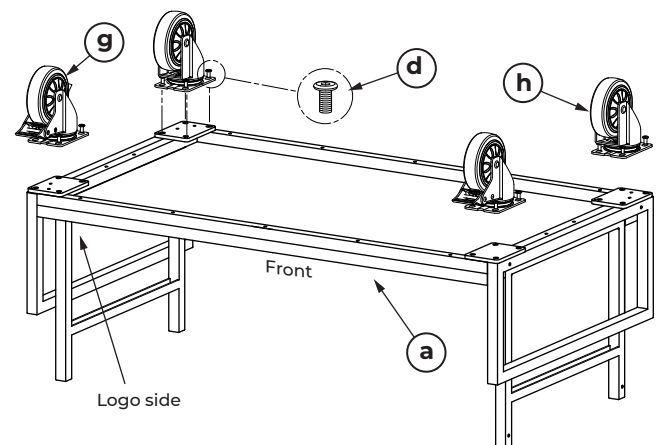

Figure 2

\* The Rubber Screw Hole Covers can be used to conceal the holes in the Back Board on units that do not include Container Mounting brackets.



#### ASSEMBLING THE CART FRAME

- Place the Base Assembly (a) upright on a flat surface. Lock the front Casters (g). Insert both Center Frames (b) into the Base Assembly (a). Install two (2) Allen Screws (d) at the bottom of both the left and right Center Frames as shown in Figure 3. The screw holes face outwards.
- Insert both Upper Frames (c) into the holes in the Center Frames (b). Install two (2) Allen Screws (d) at the top of both the left and right center frames as shown in Figure 3. The mounting pins on the Upper Frames should be facing towards the back.

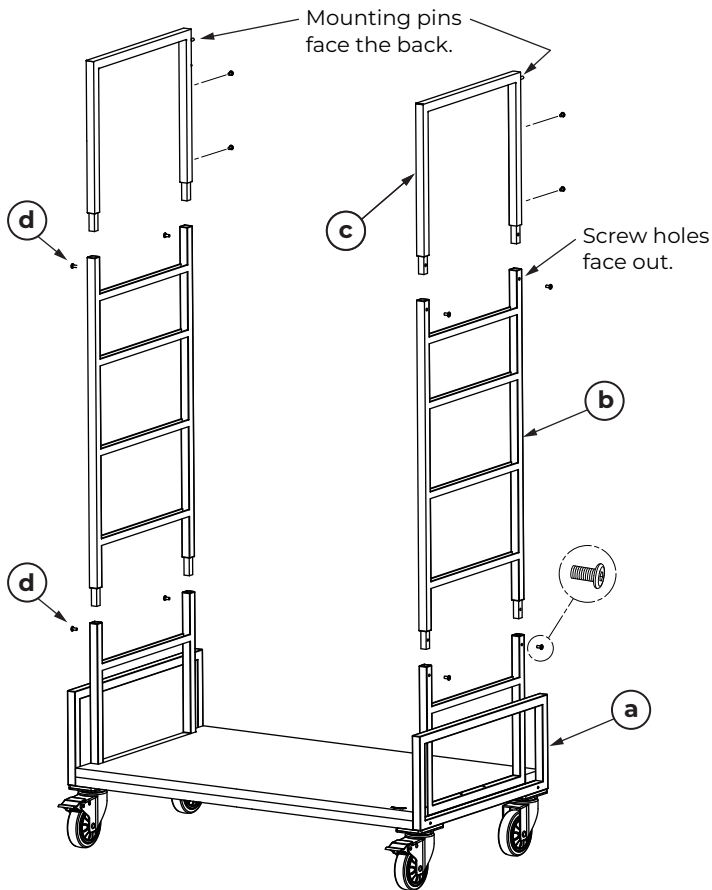

- Hang the Back Board (f) on the mounting pins. Line up all holes and install 2 Allen screws (d) on each side of the Back Board (f). Tighten all 4 Allen screws (d). See Figure 4.

#### ATTACHING THE BACK BOARD

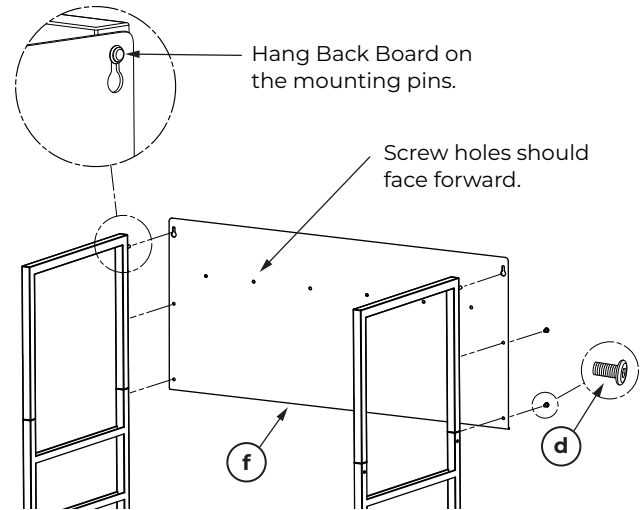

Figure 4

#### SPECIFICATIONS

ASSEMBLED DIMENSIONS	INCHES	CM
LENGTH	36"	91.44 cm
WIDTH	20"	50.80 cm
HEIGHT	61.5"	156.21 cm

WEIGHT 56 lbs/25.40 kg

#### CARE AND CLEANING

- DO NOT put any part of the unit through dishwasher or dryer machine. ALWAYS use a non-abrasive sponge.
- DO NOT use any abrasive materials such as scrapers or metal-based brushes.
- DO NOT use harsh chemicals or abrasive cleaners.

#### Metal Care:

Wipe down with damp microfiber cloth and always wipe dry with a microfiber cloth. Store in a dry and well-ventilated location.

