

BULKshop Gondola Kit B

Instruction & Specification Sheet GK2121, GK2111, GK2131

BEFORE YOU BEGIN

Be sure to read all the instructions before attempting to assemble the BULKshop Gondola Kit B.

- Carefully remove all parts from the carton and inspect each part. If a part appears to be damaged or missing, please contact Rosseto Customer Service.

PARTS GK2121, GK2111, GK2131

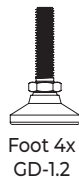
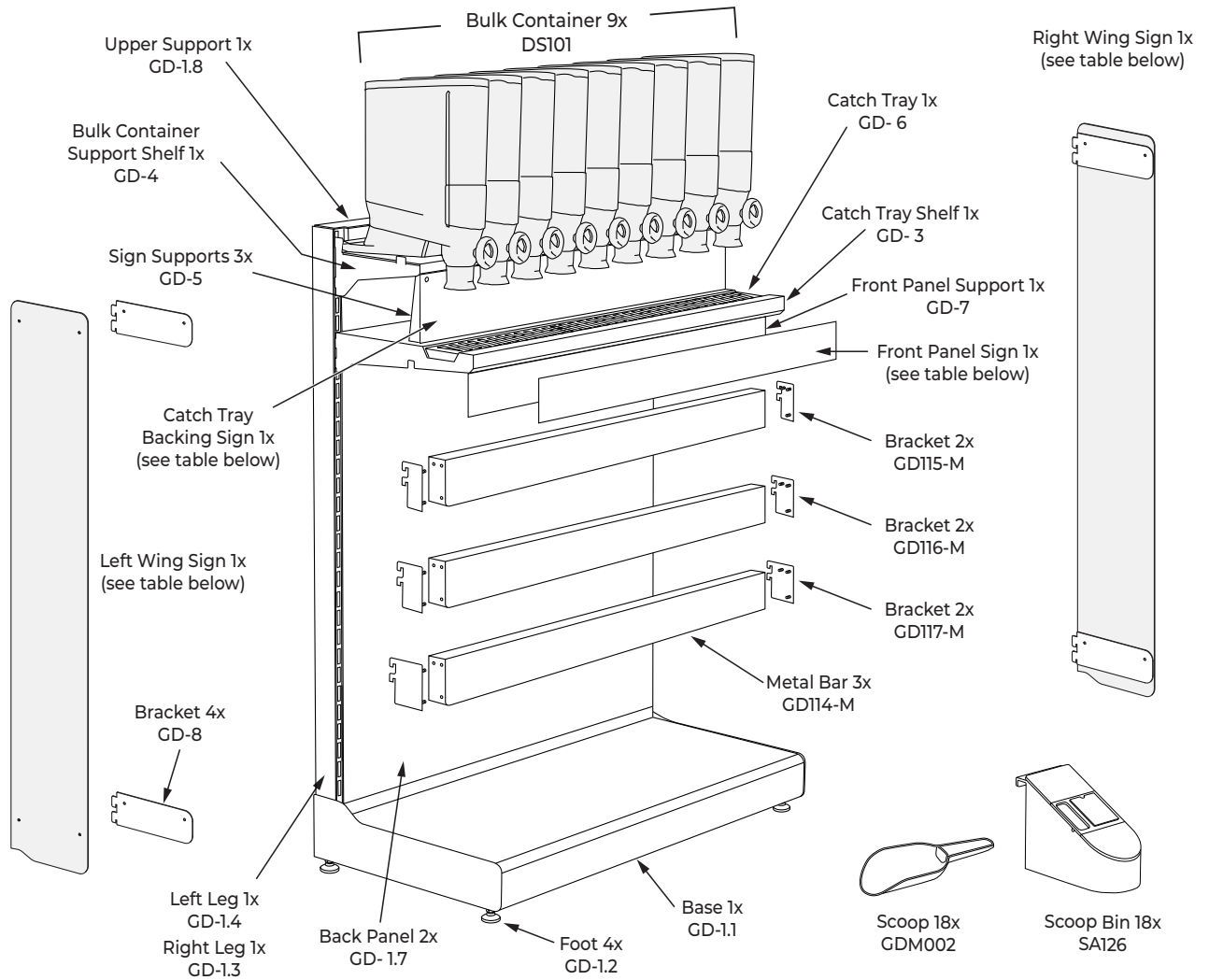

Graphic Panel	Quantity	Candy	Coffee	Natural Foods
Front Panel Sign	1x	GDS122-F	GDS121-F	GDS123-F
Catch Tray Backing Sign	1x	GDS222-B	GDS221-B	GDS223-B
Right Wing Sign	1x	GDS322-R	GDS321-R	GDS323-R
Left Wing Sign	1x	GDS322-L	GDS321-L	GDS323-L

NEED ASSISTANCE?

Customer Service Support: **847-763-1215**

Address: **3714 Jarvis Avenue Skokie, IL 60076**

Website: **www.rosseto.com**



ASSEMBLING THE GONDOLA

Assemble the Gondola on a flat and level surface.

1. Insert each Leg into the hole on each side of the Base (GD-1.1) at a slight angle to avoid scratching the Leg during step 2.

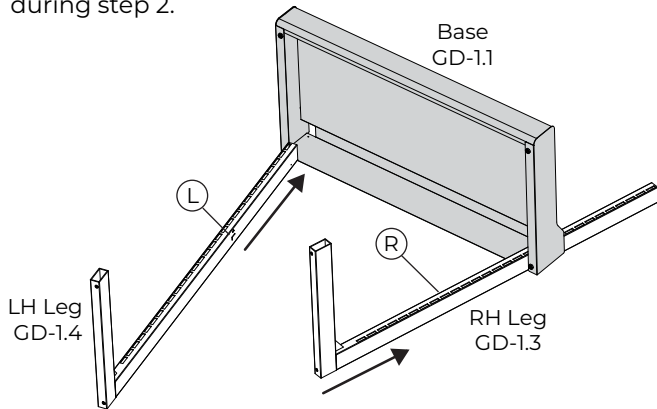

2. Slide each Leg into position. Straighten each Leg until holes in legs align with holes in base as shown below.

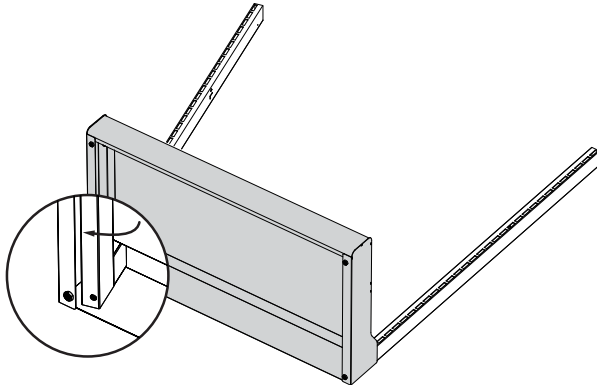

3. Screw in Foot (GD-1.2), (4 places).

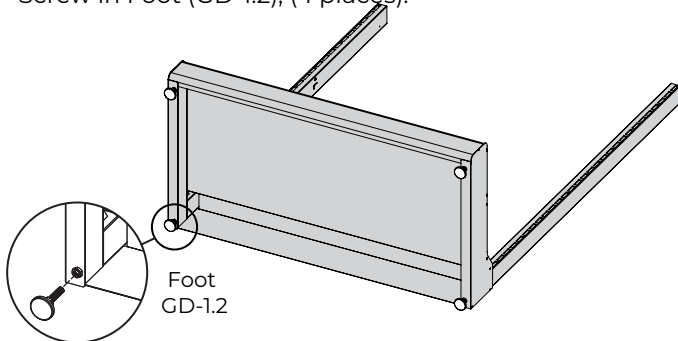

4. Adjust Feet until the Base is level (a level is not included).

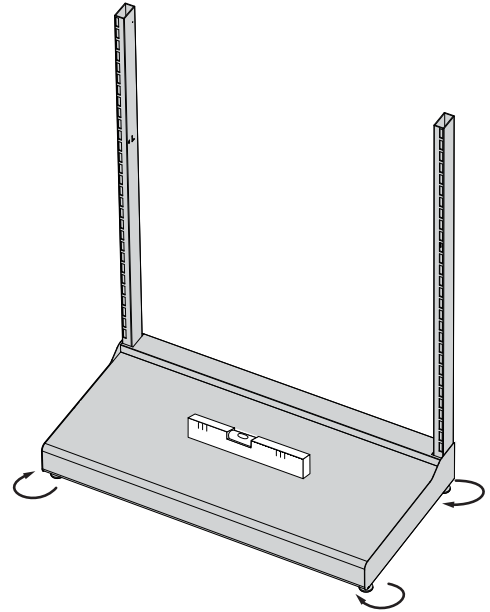

5. Install Screws (GDM005), (2 places).

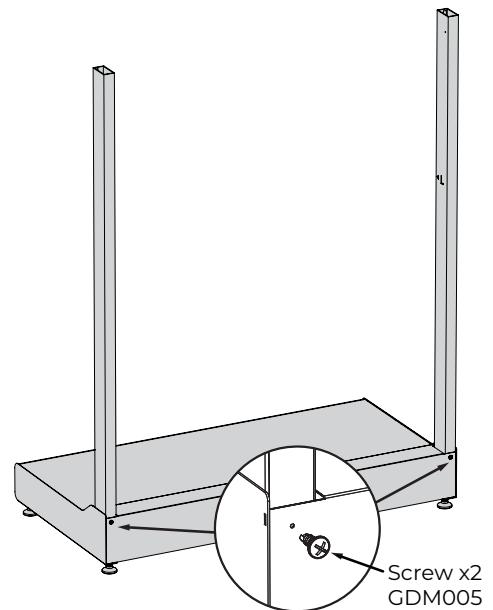

BULKshop Gondola Kit B

Instruction & Specification Sheet GK2121, GK2111, GK2131

ASSEMBLING THE GONDOLA

6. Install Back Panels (GD-1.7). Install lower panel #1 first.

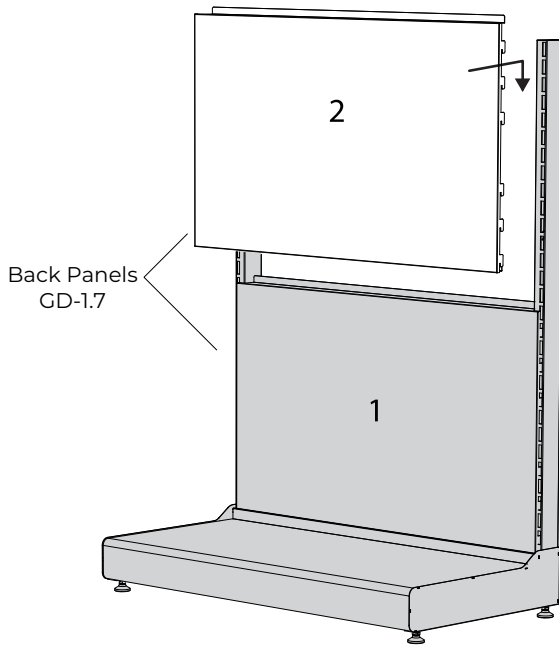

7. Install Upper Support (GD-1.8) using 2 Screws (GDM005).

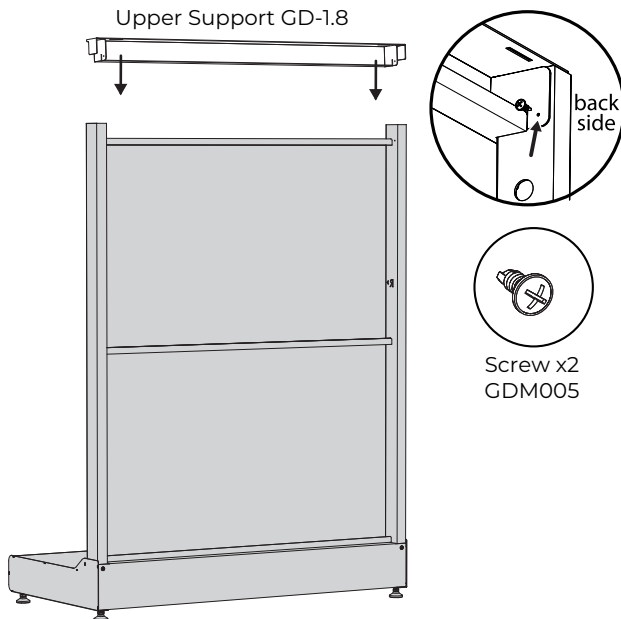

ADDING THE SHELVES

8. Attach the Bulk Container Support Shelf (GD-4) in correct slots as shown in the diagram.
9. Attach the Catch Tray Shelf (GD-3) in correct slots as shown in the diagram.

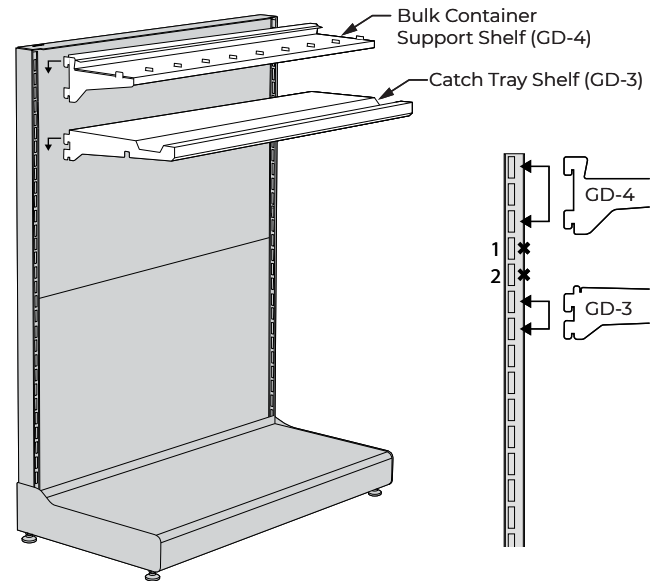

10. Insert Catch Tray (GD-6) into the Catch Tray Shelf.

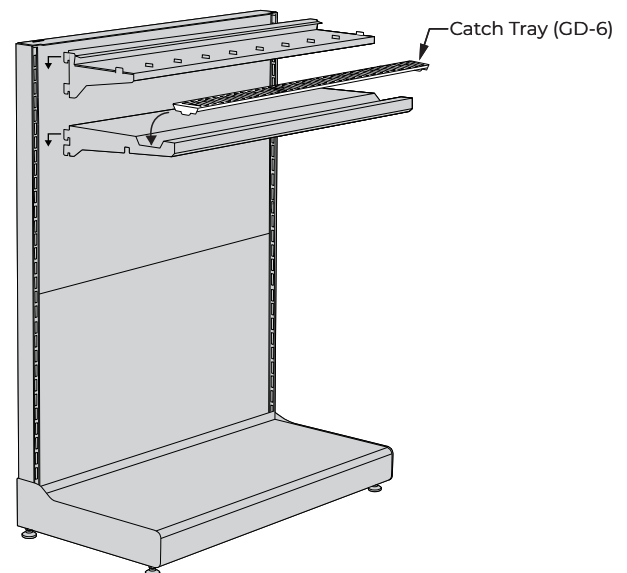

ADDING THE GRAPHIC SIGNS

Catch Tray Backing Sign Supports

11. Each Sign Support (GD-5) has a bolt welded on one end with a hex nut threaded onto the end. Remove the hex nut from the bolt. Insert the bolt end into the hole(s) in positions 1, 3, and 5 as shown in the diagram.

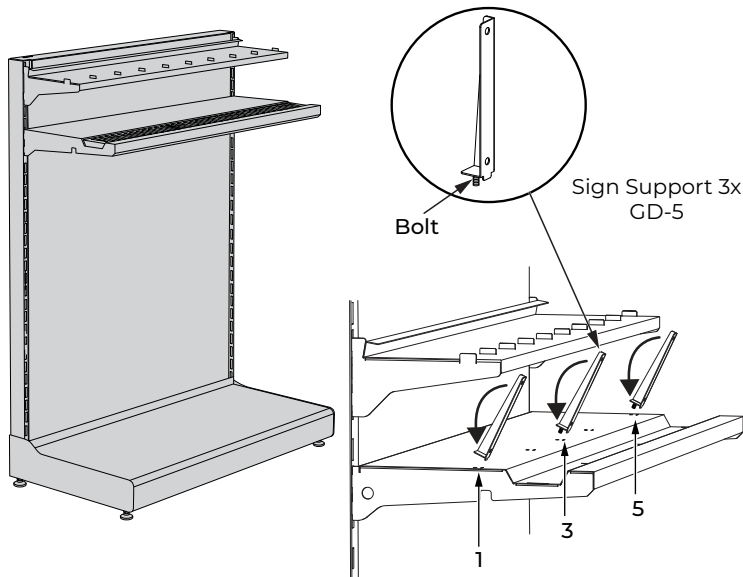

12. Secure each Sign Support (3 places) using hex nuts (GDM003).

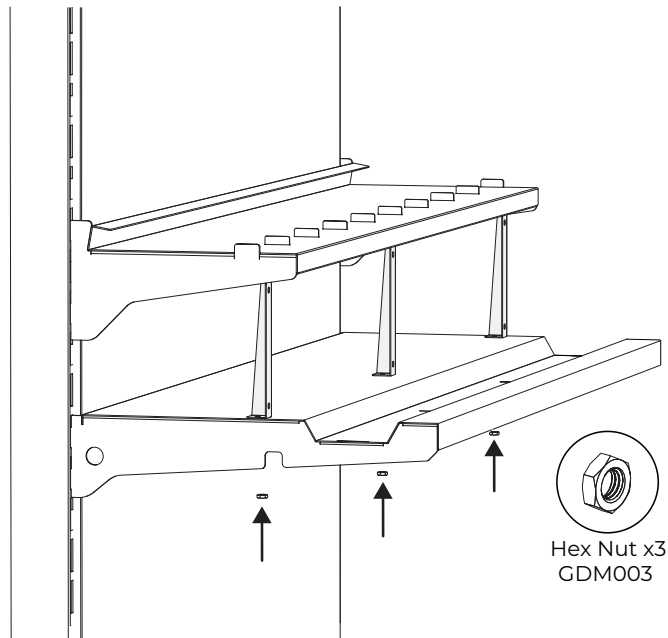

Catch Tray Backing Sign

13. Attach the Catch Tray Backing Sign using the Push-in Fasteners (GDM001).

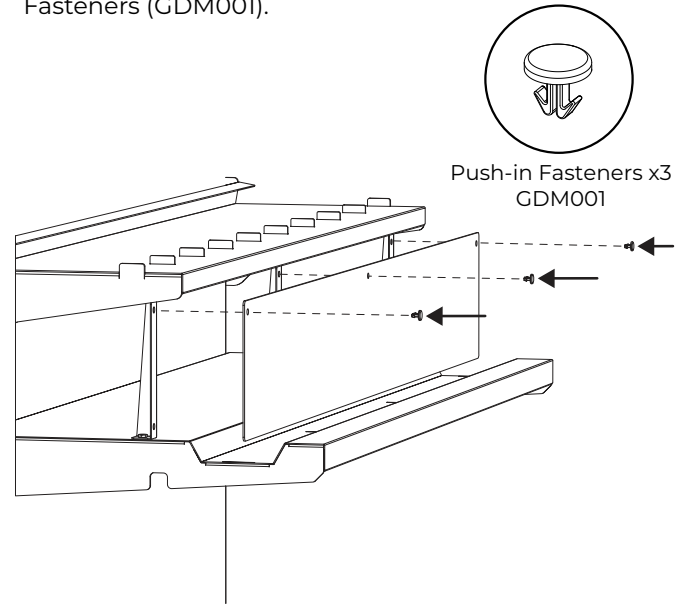

14. Attach the Front Panel Support (GD-7) as shown below. Attach the Front Panel Sign using the Push-in Fasteners (GDM001).

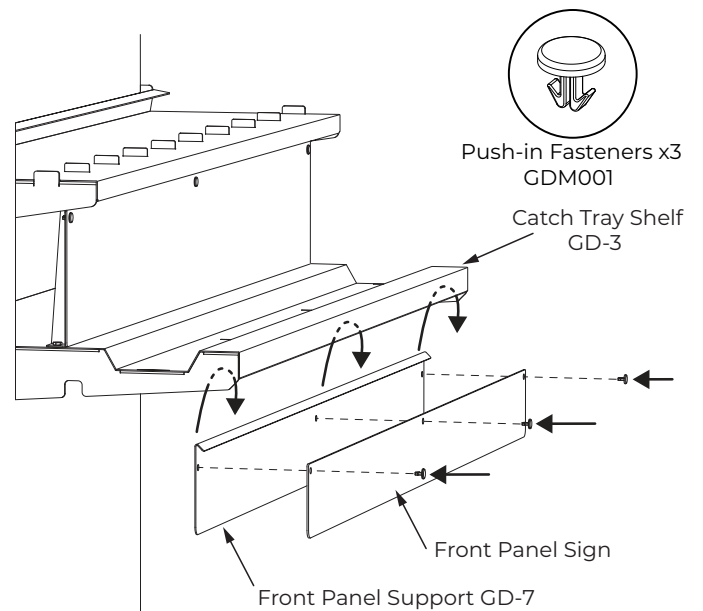

ASSEMBLING THE SCOOP BIN SUPPORTS

Attaching the Scoop Bin Brackets

15. Each Scoop Bin Bracket has 3 bolts welded onto each Bracket with a hex nut threaded onto the bolts. Remove the hex nuts from the bolts. Insert each Bracket into the holes in the Metal Bars on each side as shown below. Use 3 hex nuts to fasten the brackets to the Metal Bars.

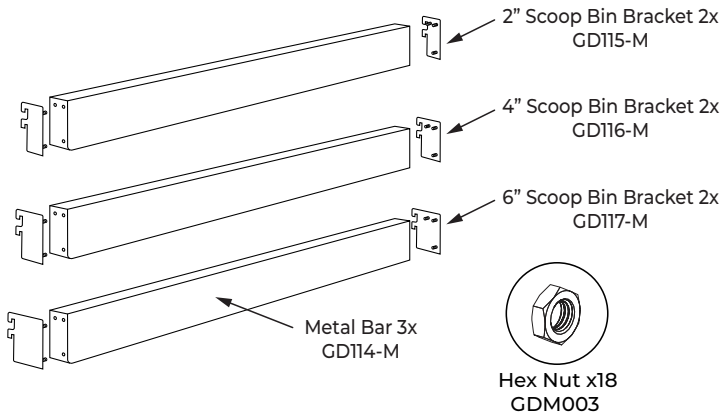

Attaching the Assembled Bars to the Gondola

16. The figure below shows the correct location for each assembled Metal Bar.

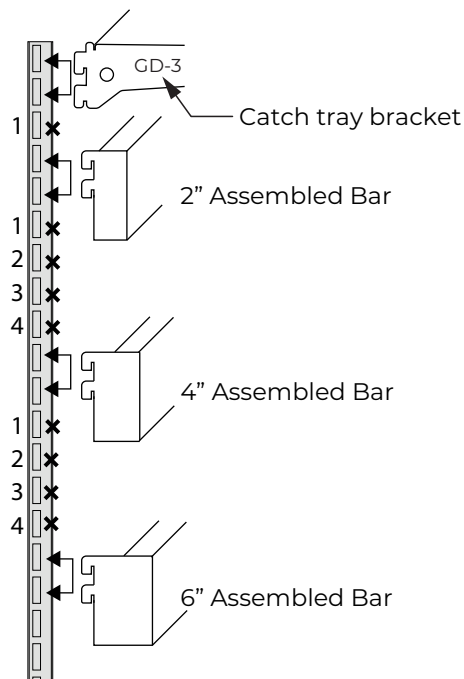

Attaching the Hook and Loop Pieces

17. **Note: Do not separate the hook-and-loop fastener pieces.**

Remove liner on one side of each hook-and-loop fastener. Stick on a hook-and-loop fastener at the locations as shown, on both sides of the gondola.

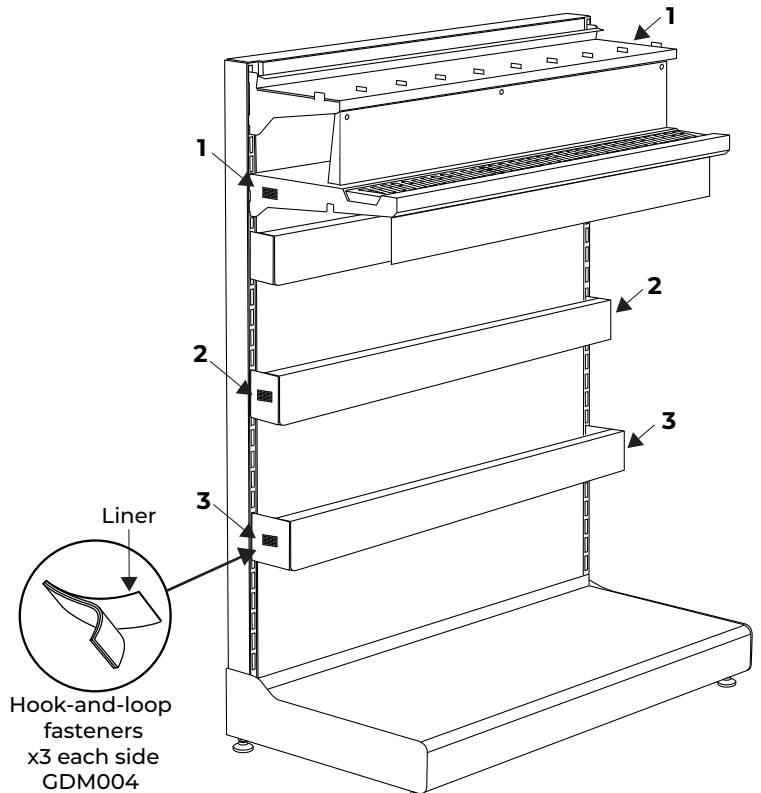

BULKshop Gondola Kit B

Instruction & Specification Sheet GK2121, GK2111, GK2131

PRINTED WING GRAPHIC SIGNS

18. Attach Brackets (GD-4) to both Wing Signs using Push-in Fasteners (GDM001) as shown below.

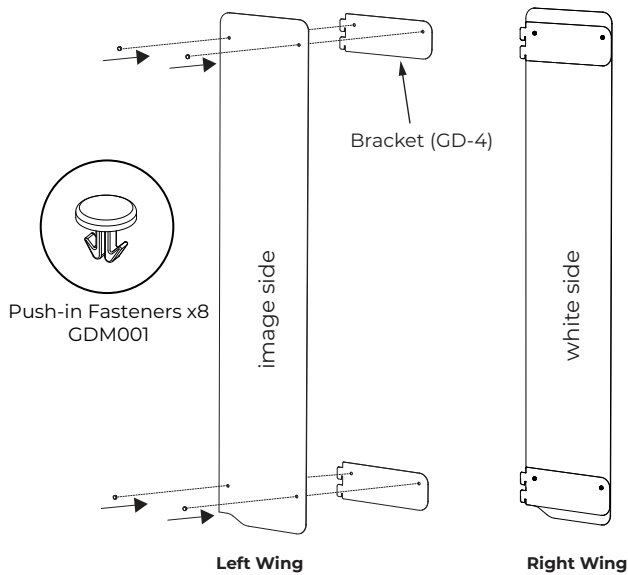

19. Insert both Wing Signs into the slots as shown below.

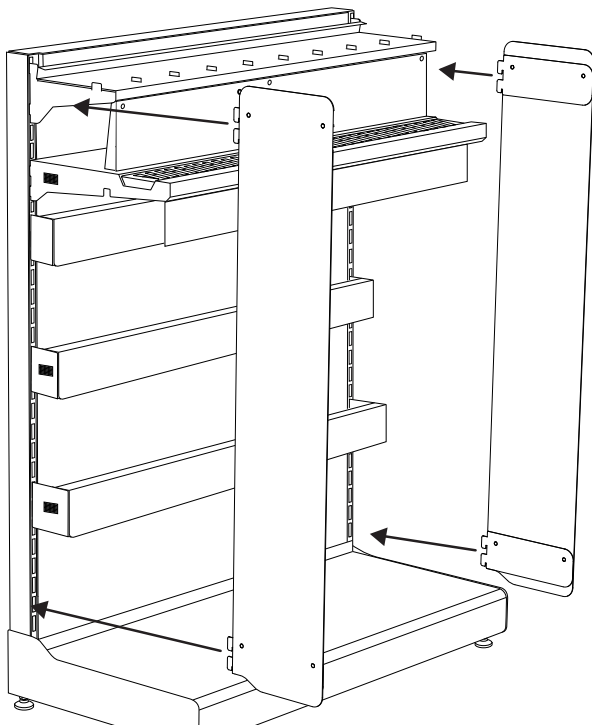

20. Swing out the Wing Signs on both sides of the gondola.

Remove the remaining liners on all Hook-and-Loop fasteners.

Press the Wing Signs firmly in place to secure.

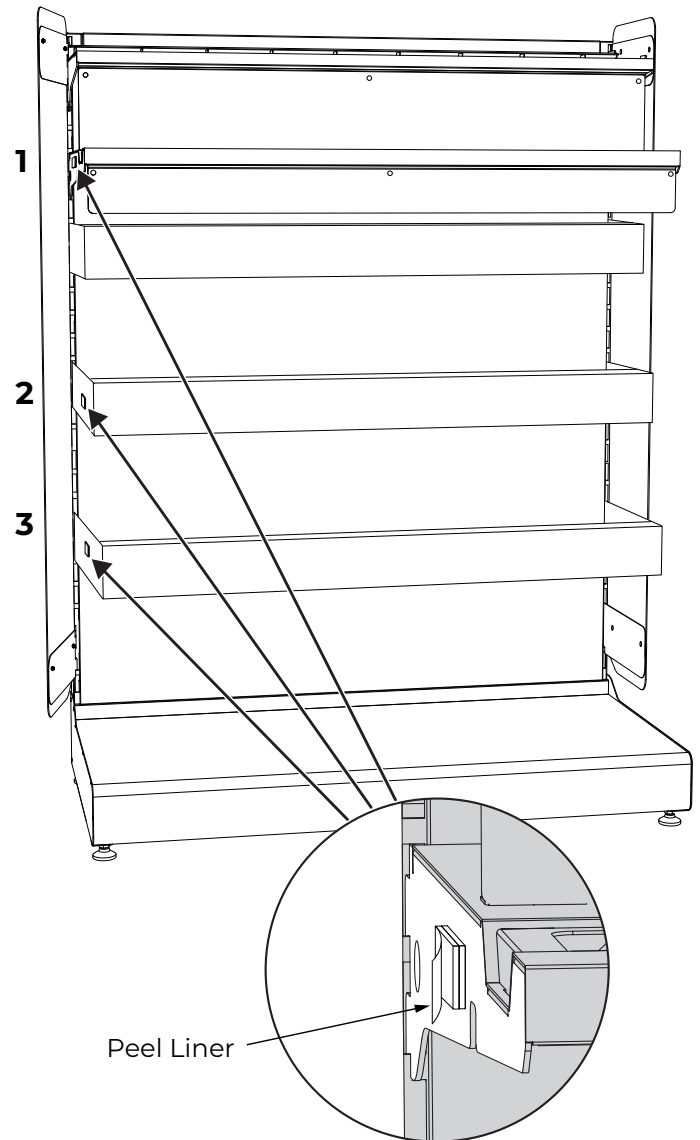

BULKshop Gondola Kit B

Instruction & Specification Sheet GK2121, GK2111, GK2131

ADDING BULK CONTAINERS AND SCOOP BINS

21. Install each Bulk Container (DS101) under the flange on the Bulk Container Shelf.

Hang 6 Scoop Bins (SA126) on each Metal Bar.

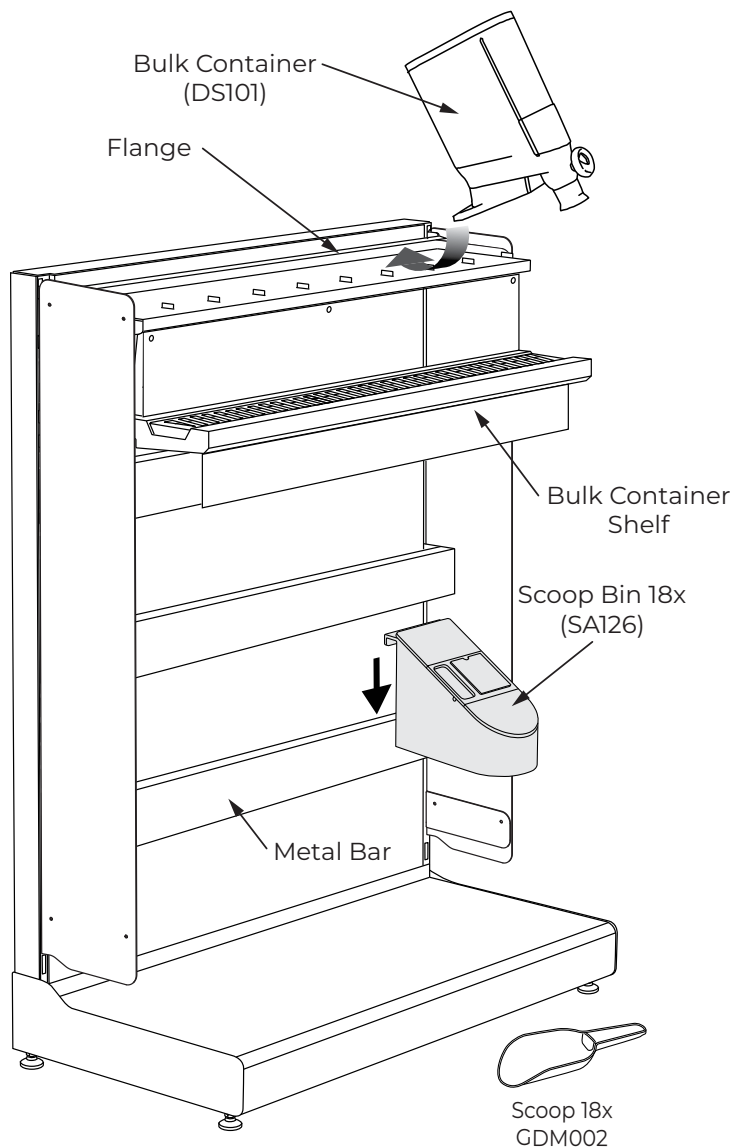

SPECIFICATIONS

ASSEMBLED DIMENSIONS	INCHES	CM
LENGTH	50"	127 cm
WIDTH	26"	66 cm
HEIGHT	67"	170 cm

WEIGHT 425 lbs/192.78 kg

CARE AND CLEANING

- DO NOT put any part of the unit through dishwasher or dryer machine. ALWAYS use a non-abrasive sponge.
- DO NOT use any abrasive materials such as scrapers or metal-based brushes.
- DO NOT use harsh chemicals or abrasive cleaners.

Metal Care:

Wipe down with damp microfiber cloth and always wipe dry with a microfiber cloth. Store in a dry and well-ventilated location.

