

PRO-BULK™ Single 3.5 Gallon Dispenser

Instruction & Specification Sheet for Model DS101

BEFORE YOU BEGIN

Be sure to read all the instructions before attempting to assemble the PRO-BULK Dispenser. Store these instructions for future reference.

- Carefully remove all parts from the carton and inspect each part. If a part appears to be damaged or missing, please contact Rosseto Customer Service.

Parts Included

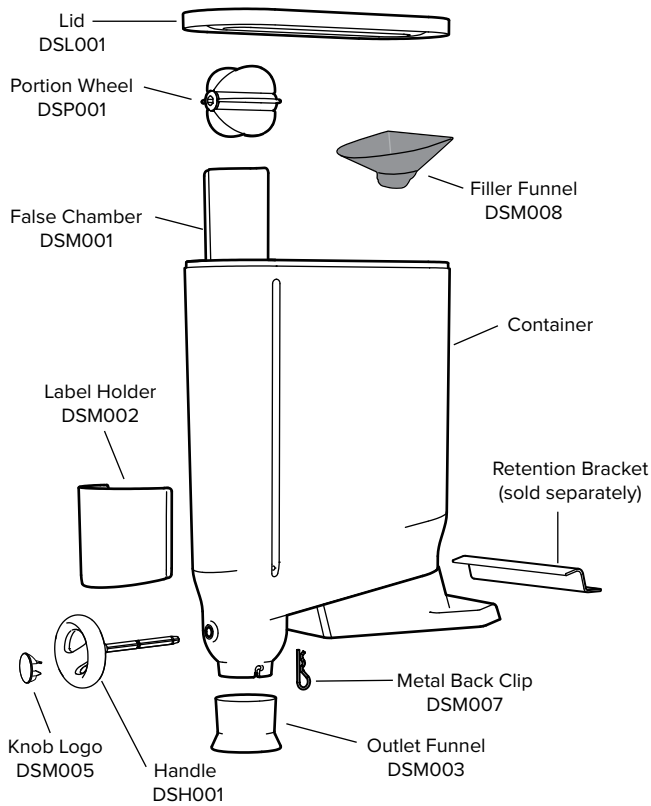

Retention Brackets Available

Part number		Length
DSM265	For use with 2 Dispensers	10.5" (26.6 cm)
DSM400	For use with 3 Dispensers	16.5" (41.9 cm)
DSM900	For use with 6 Dispensers	35.4" (89.9 cm)
DSM1209	For use with 9 Dispensers	47.5" (120.6 cm)

SETTING UP THE DISPENSER

1. Remove the False Chamber Panel from the Container.
2. Drop the Portion Wheel into the well at the bottom of the Container.
3. Insert the Handle spindle into the front hole of the Container and through the hole in the Portion Wheel until the tip of the Spindle handle is fully visible at the back.
4. Insert the straight part of the Metal Back Clip into the hole at the end of the Spindle. Push the Metal Back Clip in until the middle ridge of the Metal Back Clip rests on the Spindle (See Figure A).
5. The Outlet Funnel has 2 internal nubs that engage with the slots on the Container outlet. Slide the Funnel up and then turn to the right to lock the Funnel in place.

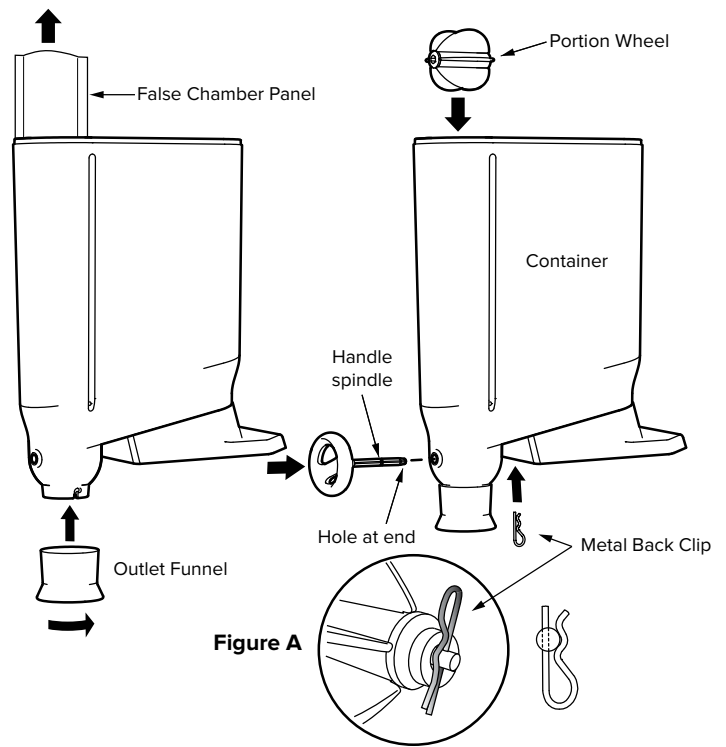

PRO-BULK™ Single 3.5 Gallon Dispenser

Instruction & Specification Sheet for Model DS101

FALSE CHAMBER FEATURE

The False Chamber Panel creates a separate chamber where food can be added to make the Container appear full even when the actual food level in the Container is low. This feature can help to reduce food waste.

1. Install the False Chamber Panel as shown in Figure 1. Note that the curve matches the curve of the Container. If the False Chamber is installed incorrectly, the product filled into the cavity area will not stay in place.
2. Using the Filler Funnel (see Figure 2), fill the false chamber with food all the way to the top. Store the Filler Funnel for future use.

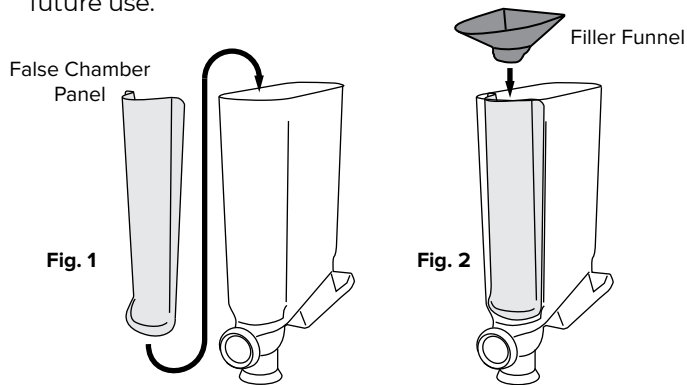

3. Fill the main chamber with desired amount of food.
4. Securely place the Lid on the Container.

INSTALLING THE OPTIONAL RETENTION BRACKET

Note: Make sure that the total weight of the Dispenser plus the weight of the food contained does not exceed the weight limitation of the shelf/cabinet the Dispenser is being placed on.

Determine how far from the front edge of the shelf/cabinet that the Dispenser will be located. Remove the adhesive liner on the back of the Retention Bracket. Press the Retention Bracket into position at desired location.

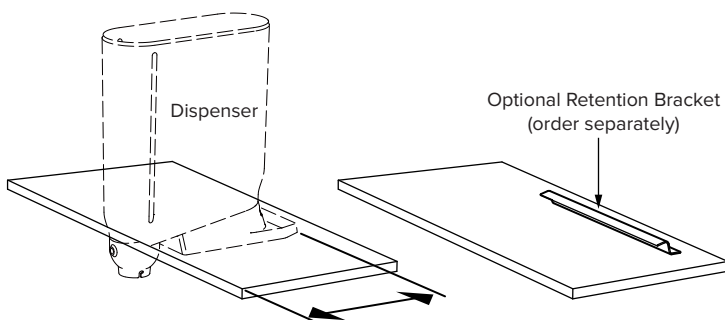

INSTALLING THE DISPENSER

1. Slide the Dispenser into position making sure the flange on the base fits under the lip of the Retention Bracket.
2. Next, rotate the Dispenser down into position. The Dispenser is now locked into the Retention Bracket.

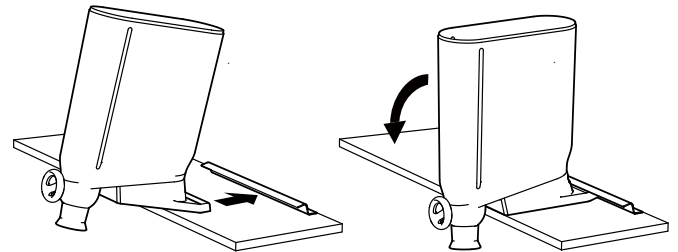

LABEL OPTIONS

Option 1

1. Print the label on paper.
2. Place the label behind the clear Label Holder.
3. Snap the Label Cover onto the Container.

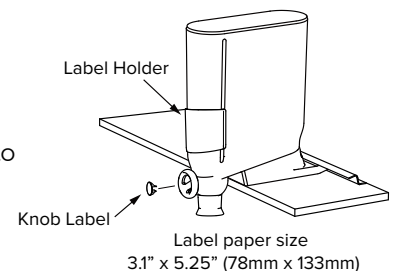

Option 2

1. Print round label onto self-adhesive paper. Cut to size (2" diameter / 50mm diameter).
2. Install onto the black Handle Knob.

CARE AND CLEANING

Wash all parts regularly using warm water and mild detergent. Allow all parts to dry thoroughly before filling with food. **A commercial metal cleaner can be used only on the exterior portion of the Handle.**

- DO NOT put any part of Dispenser through dishwasher.
- DO NOT use abrasive materials such as scrapers / brushes.

SPECIFICATIONS

Dimensions	Height	Width	Depth
	20.88"	5.3"	17"
	53 cm	13.5 cm	43.2 cm
Assembled Weight	6 Lbs. / (2.72 Kg)		

IS031-V6 040126

NEED ASSISTANCE?

Customer Service Support: **847-763-1215**

Address: **3714 Jarvis Avenue Skokie, IL 60076**

Website: **www.rosseto.com**

